

Waiver:

This data sheet is for guidance only and must not be used for proper working drawings. Please contact supplier for particular details before proceeding. Owing to our policy of continual improvement we reserve the right to alter specifications and dimensions without prior notice.

SYSTEM 21



6 Person (450kg)

NOTE: For timber frame structure supported lifts please increase the shaft widths and depths by 50mm.



Wall Mounted Models - Lifting beam supplied by builder
Structure Mounted Models - Lifting beam supplied with lift

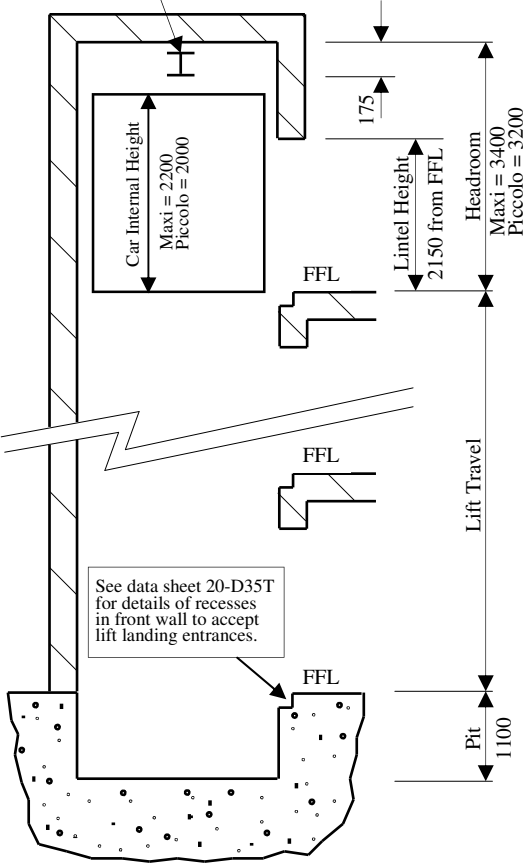

IMPORTANT

On Wall Mounted Models, Unistrut inserts ref P3270 to be built into lift pit and lift well walls by builder *before* installation. See specific Builder's Work Drawings for precise details.

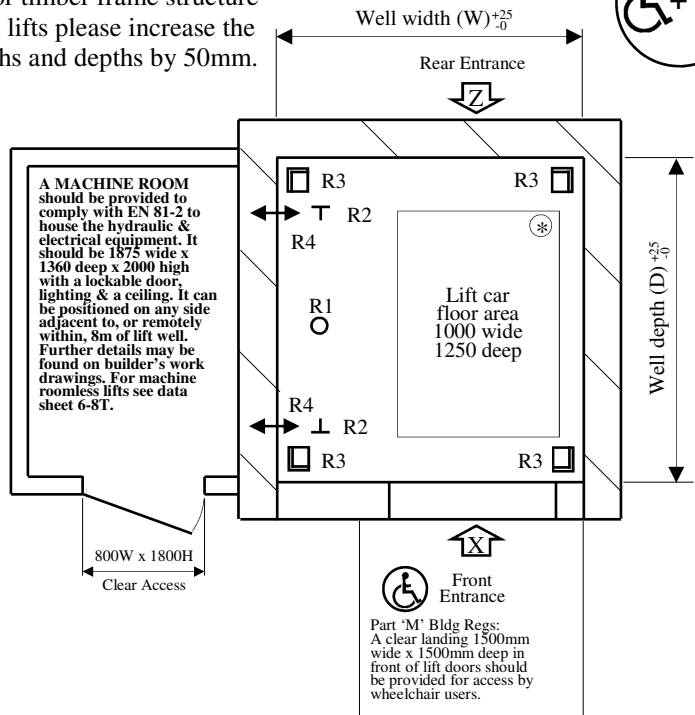

EQUIVALENT DEAD LOADS IMPOSED DUE TO LIFT OPERATION (kg)

		Wall Mounted Models	Structure Mounted Models	Type of Loading
Lift Pit Floor	R1	2710	2710	Load due to car weight + load + hydraulic cylinder
	R2	2490	2490	Load due to car buffering or safety gear operation
	R3	not applicable	797	Load at base of structure in each corner
Side Wall	R4	197	100†	Push in/Pull out load

†Applies to lift structure on all sides in the pit, headroom, at each floor level, and at a maximum of 4m intervals.

MODEL REF	LIFT DOORS ARRANGEMENT	WALL MOUNTED MODELS				STRUCTURE MOUNTED MODELS				Lift Car Clear Entrance	
		PLAN WELL DIMENSIONS				PLAN WELL DIMENSIONS					
		Front Entrance X or Z		Front & Rear Entrance X & Z		Front Entrance X or Z		Front & Rear Entrance X & Z		W	H
P6-2S 2S M6-2S 2S (800)	Auto 2 panel side opening 2S	W	D	W	D	W	D	W	D	800	2000
	Car & Landing Door Type	1475	1640	1475	1860	1630	1725	1630	1860		

Note: Shaft sizes are for guidance purposes only and subject to change. It is crucial that you contact the supplier concerning your specific requirements.



* Part 'M': This model complies with the dimensions of Part 'M' of the Building Regulations for lifts installed in a dwelling. Buildings other than a dwelling require a lift with a capacity of 8 persons or more.

EN81-70: This model is also designed to take a manual or class A electrically powered wheelchair in accordance with BS EN81-70: Accessibility to lifts for persons including persons with disability.

6-7T
11/11/08