

Machine Room Cabinet

MRC Passenger Lift



Including all associated Control Cabinet, Electrical Isolators, Distribution Boards, Power Sockets and Lighting

The Machine Room Cabinet (MRC) option gives the customers even more choice. Doing away with the need for a motor room, the space-saving design cleverly houses the motor in a cabinet that can either be located on, or recessed into an adjacent wall. If space is limited beside the lift, the MRC can be located remotely up to 8 metres away.

Hydraulic Machine Room Cabinet (MRC) features include:

- **Space Saving**
- Reduced Pit Depth
- No Increase in Lift Well Dimensions
- Flexible Design
- Easy Emergency Lowering and Evacuation
- Safe & Convenient
- Latest Hydraulic Technology
- No Excessive Loading on Shaft
- Reduces Building Costs
- Through & Adjacent Entry Available
- **Ideal Lift Frame** option available

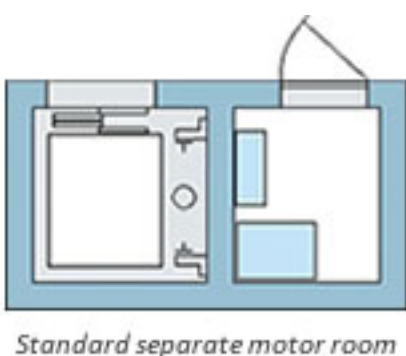
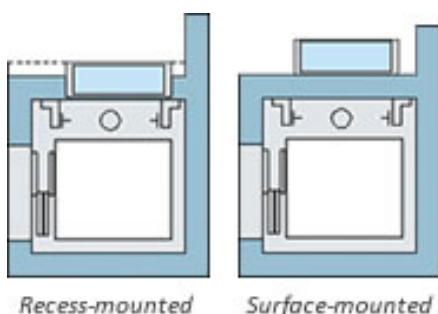

For further information, please contact Ideal Lifts or visit our website to download specific product literature and data sheets:

ideallifts.com

